



EBG V1 Electronic Break Glass

Installation Note

The EBG is a break glass unit used with electric locks to enable local, emergency unlocking of electronically controlled doors.

The EBG features local, automatic and remote reset options, LED status indication and audible activation alarm.

Introduction

The Jack Fuse Electronic Break Glass (EBG) is used as a means for building occupants to open electronically controlled doors in the event of a local emergency or system failure.

The EBG provides the unique ability to be remotely and/or automatically reset. This provides a distinct advantage over all other break glass types and reduces the issues associated with nuisance break glass alarms.

The EBG consists of an attractive case, back lit actuator, redundant activation switches, electronic latching circuit, activation guard, wall and case removal tamper switch and a base with industry standard mounting options.

Modes - Summary

The Electronic Break Glass has two primary operating modes. The mode chosen depends on security level and automation requirements.

Lock power control mode. This is the most used mode and utilises the standard lock power available at a door to power the EBG and control the reset function. Typically, this mode requires no special cabling, is suitable for most electronically controlled doors and for upgrading legacy manual break glass units.

Dedicated power control mode. This mode uses a 12 or 24DC voltage supplied by a dedicated cable to power the EBG and control the reset function. Dedicated power control is useful when facility or security managers want more control over when their break glass units should be reset.

Both modes allow remote and automatic reset.

See the *Reset Methods* and *Installation – Connections* sections of this manual for more information

Operation

During normal door operation the EBG shows a green LED indication behind the actuator. To facilitate an emergency escape via an associated locked door, the user lifts the activation guard and presses the large actuator. Once pressed, the back lighting turns red and the warning sounder is activated. The EBG immediately cuts power to the electric lock, thus unlocking the door and allowing building occupant(s) to escape.

A core function of the EBG is the ability to be automatically, remotely or locally reset after activations. See the *Reset Methods* section for more detail.

LED back lighting brightness and the warning sounder volume can be adjusted or even disabled to suit customer requirements.

A second relay contact within the EBG can be used to control a second door, or, more commonly, be connected to an alarm input for the purpose of monitoring the break glass status and alerting security staff to a break glass activation.

A built-in tamper switch monitors for both case opening and removal of the EBG from the wall.

Reset Methods

Once activated (Red) the EBG will need to be reset before the associated door can relock. The EBG features three reset options, local, automatic and remote.

Automatic reset. If enabled, an automatic reset of the EBG is achieved by cycling lock power On-Off-On. This can be done by swiping a valid card at the associated reader, pressing an exit button or by having the lock power turned off and on via the access control system.

In automatic reset mode, unlocking and then relocking of a door on a time schedule will also automatically reset the EBG. This is useful for remote facilities. If the EBG has been activated at night, it will reset once the door unlocks in the morning allowing the door to automatically relock as intended on the next schedule later that day.

Note that the automatic reset function can also act as a remote reset. A system operator may choose to manually unlock and lock the door to reset the EBG.

Remote reset. If enabled, a remote reset of the EBG is achieved by cycling power to the VDC terminal. On-Off-On.

The remote reset signal can be configured in several ways (See the *Installation – Connections* section for details) and methods may include a simple button at a security desk or even an output controlled via security software. The output may be controlled manually, set to an end of day schedule or programmed via logic to activate periodically or automatically when the system detects a break glass activation.

Remote reset can be configured to control an individual EBG unit or a group of EBG units depending on facility requirements.

Local reset. A reset button is located on the underside of the EBG. Insert a 2mm terminal driver (or similar shaped tool) gently into the hole marked with a reset symbol  until a resistance and then a click is felt. The break glass will then reset.

Override

Local override. It may be beneficial to override the EBG to keep a door unlocked. For example, to allow furniture removalists to come and go or to work on the electronic lock without the chance of a reset and short circuit. The EBG features a manual, local override that will bypass reset options and keep the door unlocked until the override is removed.

To override the EBG locate the override security screw on the bottom of the unit next to an ajar door symbol. Gently turn the screw clockwise using a T10 security Torx driver until resistance is felt. The EBG will activate.

To remove the override simply turn the override screw counterclockwise several turns and then press the local reset button.

Tip: When the EBG is in override mode, the reset button can be pressed briefly to test the connection or electric lock. Note that the EBG will revert to override mode as soon as the reset button is released.

Warning: When in override mode do not press the reset button for more than one second.

Note. If the EBG PCB is not centred properly the override screw may not align with the override switch. This can be easily fixed by loosening the four PCB screws and adjusting the PCB position before re-tightening the screws.

Fig. 1 Local override and reset

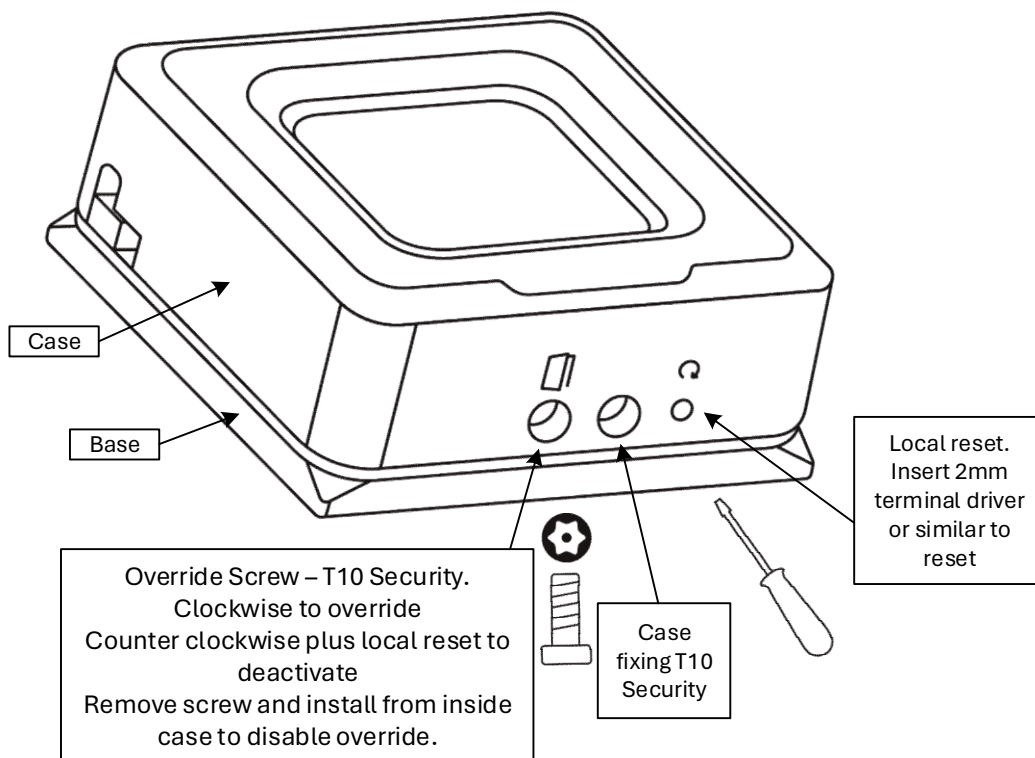

Override disable. The local override option can be disabled thus preventing un-wanted overrides.

The override is disabled by removing the override screw and threading it back into the same hole from the inside of the EBG. This blocks the override hole/switch completely and prevents a new screw being used as an override.

Steps:

1. Turn the override screw counterclockwise until it comes free from the housing.
2. Retain the screw and open the EBG unit.
3. Remove the EBG control board by undoing the four retaining screws.
4. Insert the override screw into the inside thread of the override hole.
5. Turn until the screw head meets the case.
6. Re-install the control board ensuring the screw head does not foul on the override button.
7. Close the EBG unit and ensure it can be reset.

Installation Precautions – Important MUST Read.

The EBG contains more complex electronics than a traditional manual break glass unit. Simple steps should be taken to prevent damage to the EBG and other system components.

Over current protection. To comply with standards/wiring regulations and protect the cable/EBG unit, overcurrent protection in the form of a fuse must be implemented on any power circuit used with the EBG. Lock power current must be limited to 3A or less. Note that the standard practice of providing a lock power fuse at the power supply panel will be sufficient protection for the EBG lock power circuit.

A short circuit on the cable or at the lock and failure to implement overcurrent protection may result in damage to the cable and/or the EBG relay(s).

Take care to terminate the VDC connection with the correct polarity.

Disconnect power before terminating. As with all electronic devices it is important to not terminate live/powered cables. Damage may occur if a live conductor accidentally touches the EBG components or other security equipment.

An effective and efficient method of disconnecting power is to have the door overridden to free mode while working on the EBG.

Activate the EBG before working on electric locks. An accidental short circuit at the lock may damage the EBG, lock power cable or the power supply. To avoid this, activate the break glass to drop power from the lock before replacing or repairing the electric lock.

Installation – Retrofit to replace manual break glass.

An EBG can be retrofitted in place of a standard manual break glass unit. In most cases new cables will not be required and the automatic reset feature can be enabled using existing lock power cabling.

The EBG base footprint will match/cover many legacy break glass footprints and may even utilise the same wall fixing holes.

Installation – Automatic Doors

An automatic door, gate or roller shutter typically requires a dry contact activation signal. There are two ways to achieve this using the EBG.

Remote reset mode. If the EBG is being supplied with a dedicated VDC remote reset signal, then either of the relay contacts can be used to provide a dry contact signal to the automatic door controller.

Automatic reset mode. If automatic reset mode via lock power control is preferred, then the EBG should be installed using the same method as a fail-safe electric lock. This method will provide a VDC signal. This signal is then converted to a dry contact using the Jack Fuse **Mini-FRI** interface relay. Ideally the Mini-FRI relay would be located close to the door or gate controls.

In this manner the automatic reset, LED lighting and activation sounder features can be maintained while still providing fail-safe emergency opening of the automatic door.

See the *Installation – Connections* section for automatic door connection drawings.

Installation - Physical

Base mounting. The EBG base can be mounted directly to the wall using the holes provided.

Mounting holes and screws are also provided that allow the base to be fitted to the optional EBG back box, an electrical wall box or existing break glass mounting box.

Retrofit. To enable efficient retrofitting, the EBG mounting hole pattern matches many legacy manual break glass units. The base is slightly larger which helps cover old paint lines.

Fig. 2. Base & mounting options

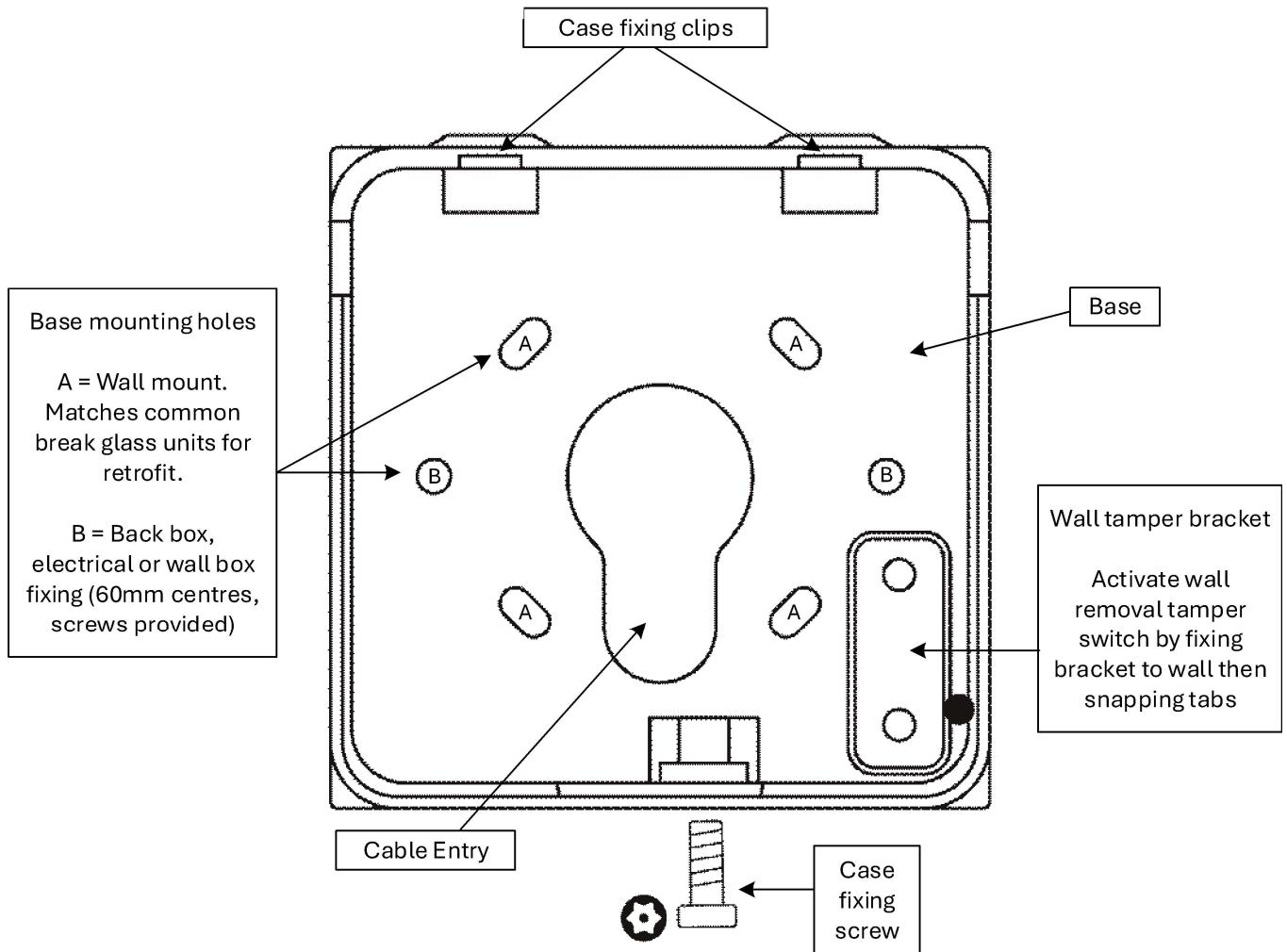

Wall Tamper. The case tamper switch can optionally monitor the EBG for removal from the wall. The wall tamper bracket is attached to the base by small tabs that need to be broken to activate the wall tamper.

Fix both the base and the wall tamper bracket to the wall at the same time. Remove the base fixing screws and pull on the base to snap the bracket tabs. This will leave the wall tamper bracket in place on the wall. Re-affix the base as normal.

Note: If mounting the EBG on a back box, electrical wall box or legacy break glass base, do not detach the wall tamper bracket.

Note: Ensure the EBG mounting surface is stable and not subject to excessive movement or shocks. Adjust/repair doors to prevent slamming.

Fitting the case. Attach the case to the top clips of the base at an angle then press in to seat the case. Install the provided T10 security screw and tighten until the head of the screw is flush with the case.

Fig. 3. Case fitting

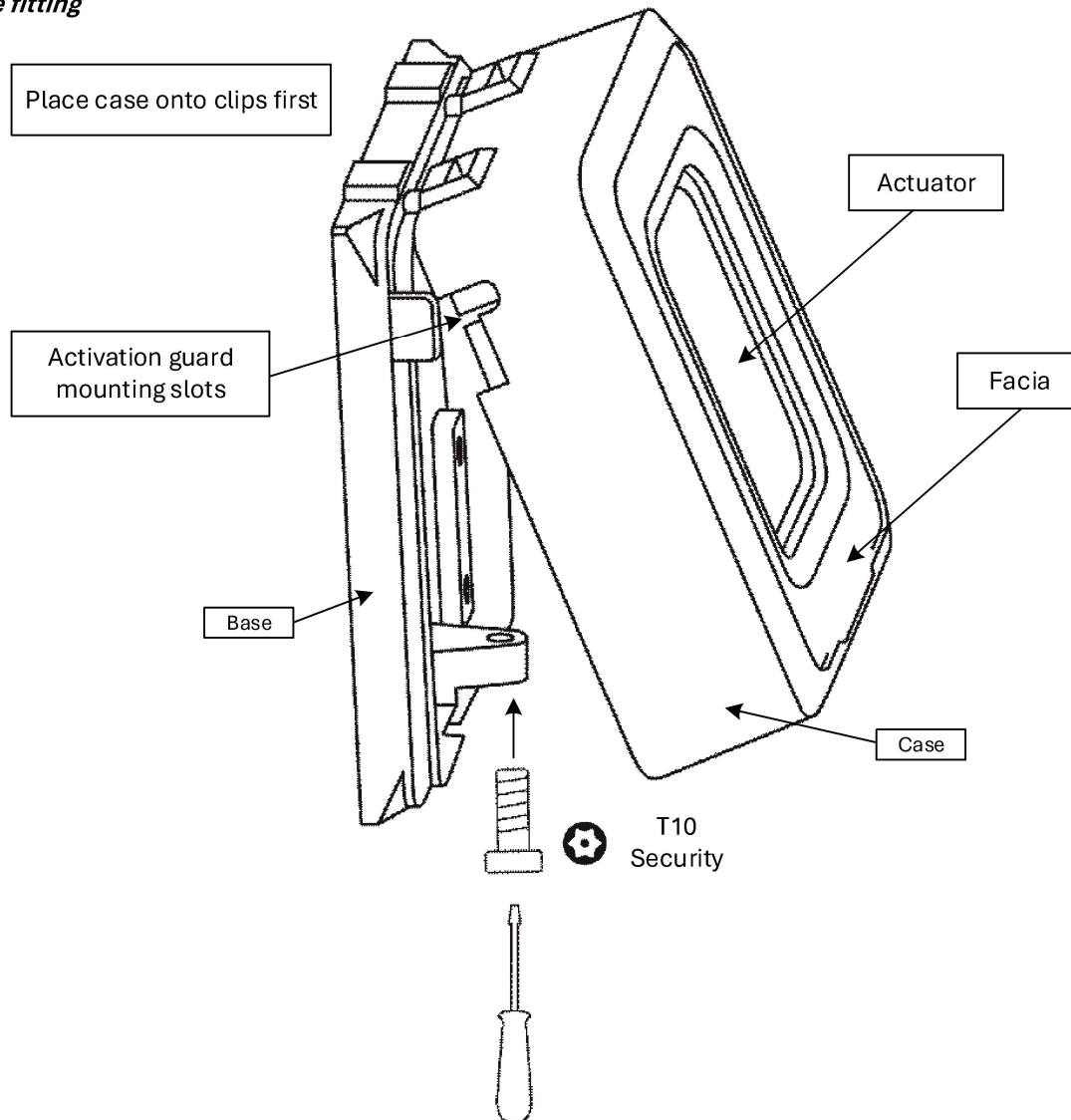

Actuator reversal. The running man symbol printed on the actuator can be reversed to match the door or escape direction. Carefully remove the four screws holding the printed circuit board, remove, flip and replace the actuator. Replace the circuit board screws taking care to not overtighten.

Facia replacement. By default, the EBG is supplied with a green facia on which is printed “EMERGENCY DOOR RELEASE”. Custom facia colours, text and branding can be ordered from Jack Fuse. To replace the facia, open the case and use a flat bladed screwdriver to carefully disengage the six facia clips. This can be done without removing the circuit board. A new facia can be pressed in from the front of the case.

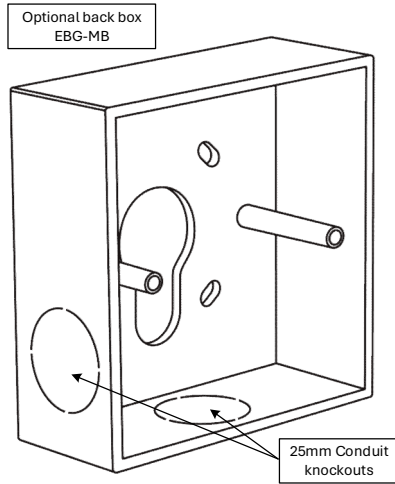

Fig. 4. Optional surface mounting back box

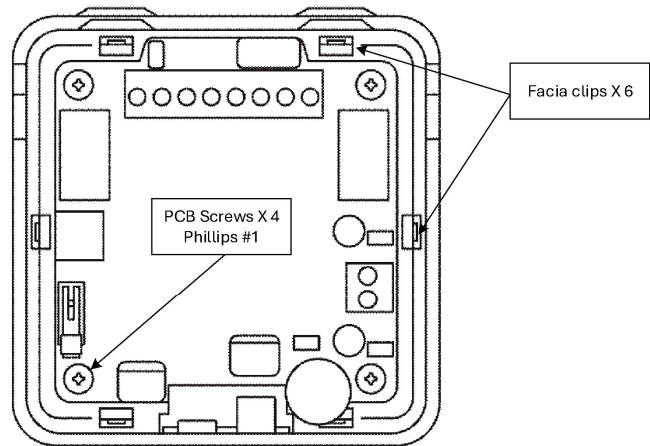
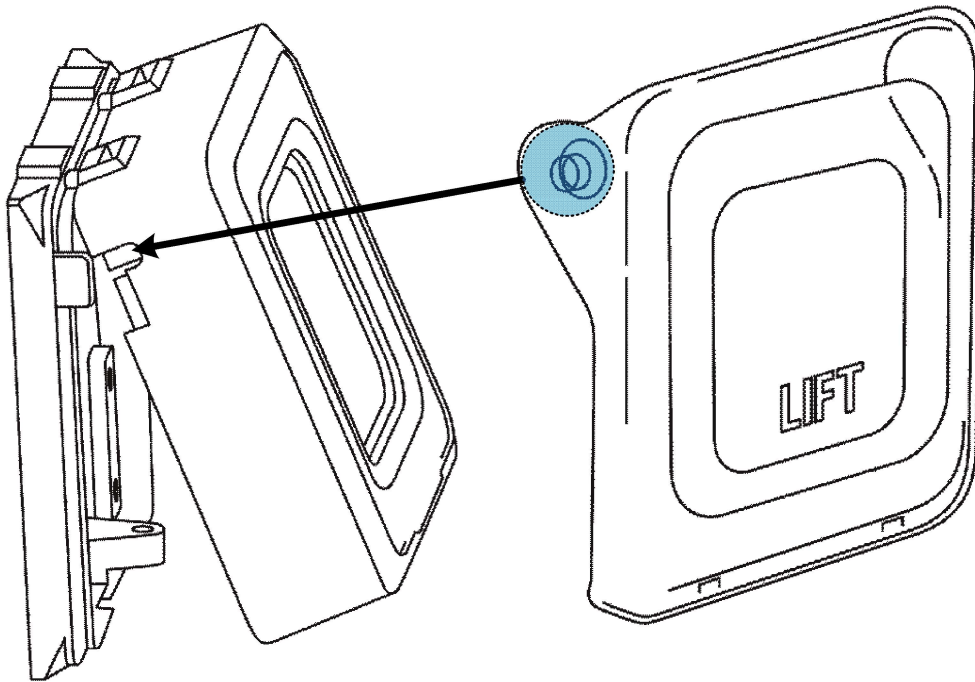

Fig. 5. Facia clips and PCB fixing



Activation Guard. To install the activation guard, the case must be removed from the base and the guard pivots fitted into the slots on either side.

Installation – Settings – Quick Reference

Quick reference only. Please refer to individual sections for full instructions. Colour of text box matches setting section heading.

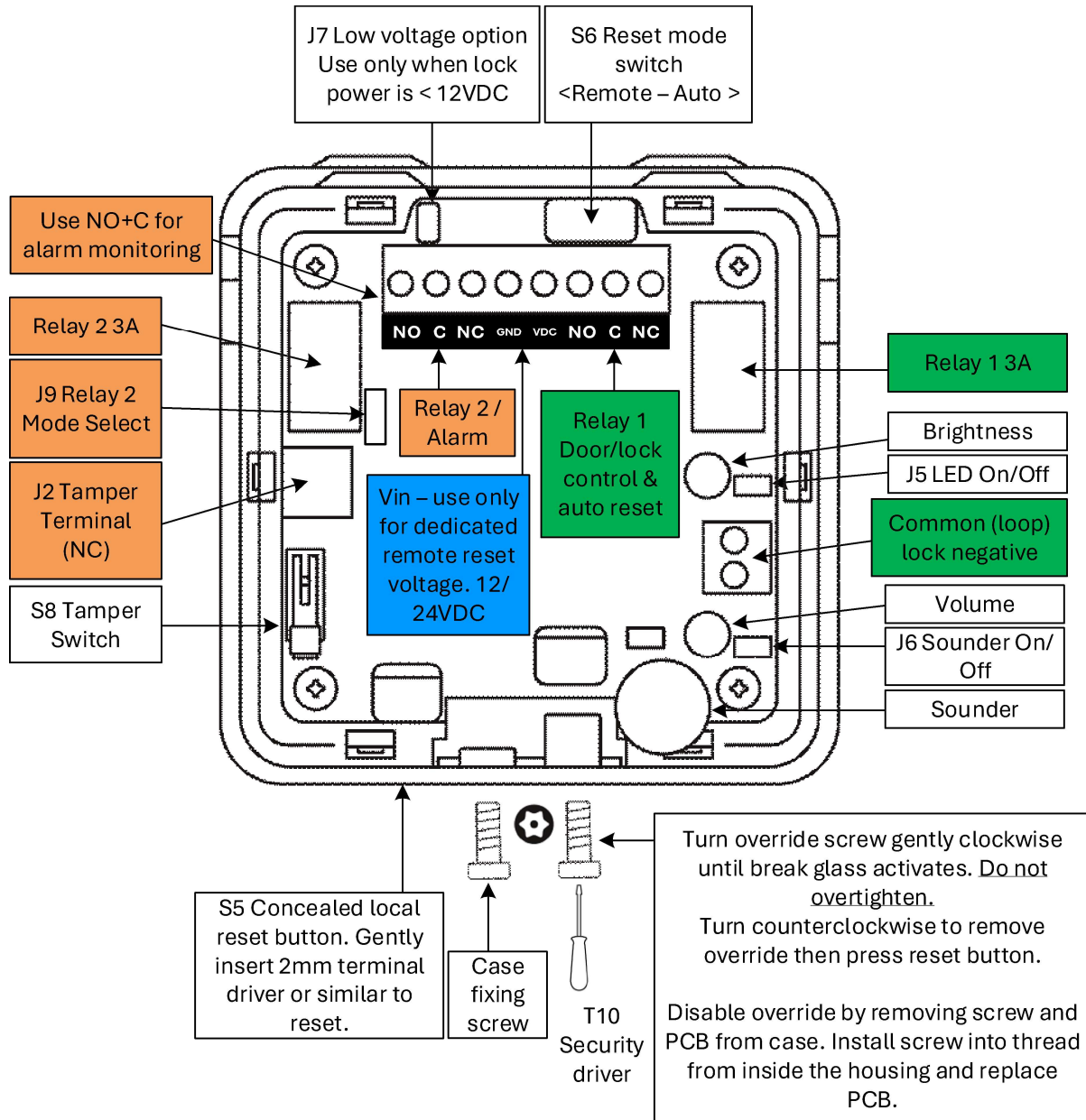

Fig. 7. Quick reference

Installation - Connections

Electronic Break Glass Connection Methods. There are two main connection methods.

- 1) Lock power control
- 2) Dedicated power control

Warning: Lock & dedicated power must be protected by upstream fuses to prevent damage to the EBG, cable and power supply due to short circuit. Jack Fuse recommends using a protected power distribution module from the Power Port range. See the *Installation Precautions* section for more information.

Lock power control

This method of connection is the most common and is very similar to traditional break glass wiring. Upon activation the EBG simply interrupts the positive side of the lock power circuit to unlock an electric lock.

Lock power control is also typically used when upgrading from a legacy manual break glass to the EBG. Using lock power control means no new cables are required for most retrofits.

The EBG uses standard lock power to energise a latching circuit, illuminate the LED back lighting and activate the sounder.

Connect the lock power to the EBG J1 terminal ensuring the positive VDC feed from the access control panel is terminated to the common (**C**) terminal of relay 1. Marked **LOCK + IN**.

Connect the positive side of the lock cable to the **NC** terminal of relay 1. Marked **LOCK + Out**

The common/negative conductors from both the lock and the access control panel must be connected together via the **LOOP** terminal. This terminal provides a ground or common connection for the EBG electronics.

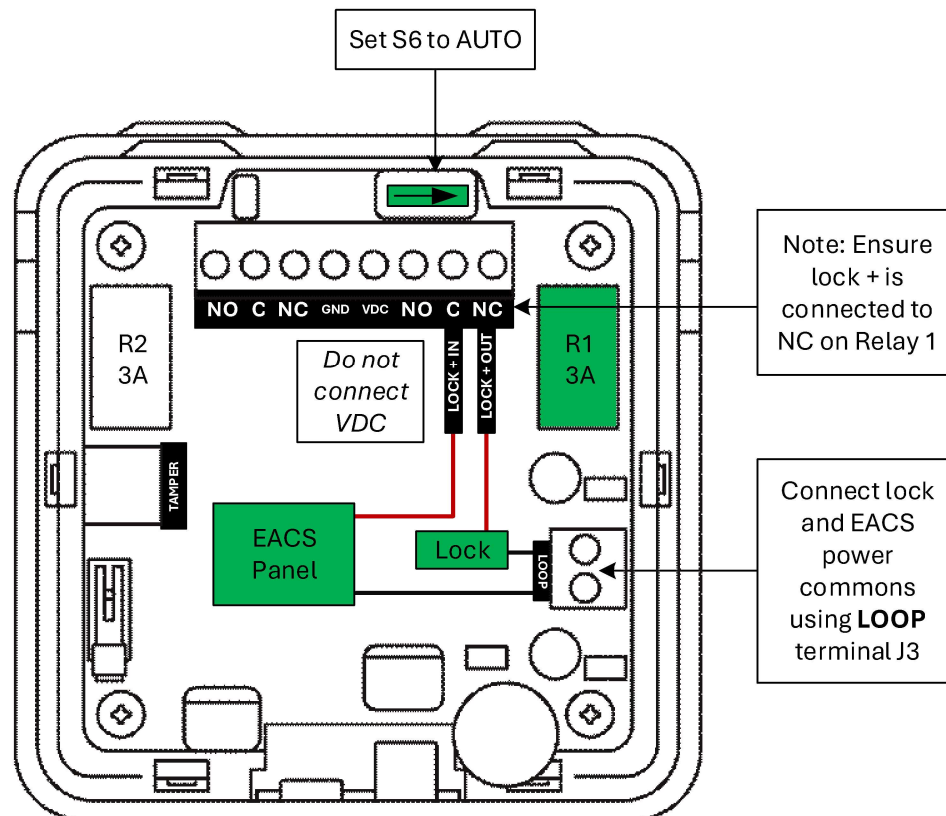

Fig. 8. Lock power control

Dedicated power control

Using a dedicated DC voltage to power the EBG allows a reset to be provided by a remote push button, key switch or system relay. This is beneficial for facility managers wanting to control when the EBG is reset.

Using this method the EBG is reset by momentarily interrupting the control voltage (one second minimum). Use a momentary normally closed switch (NC) that goes open to cut power. The EBG will deactivate once reset power is restored. The control voltage and interrupt signal can be common to all EBG units in a facility or separated to allow reset of specific units.

A separate two conductor cable is required to provide the dedicated control voltage. Connect this cable to the **GND** and **VDC** terminals of J1 taking care to observe correct polarity.

Fig. 9. Dedicated power VDC control

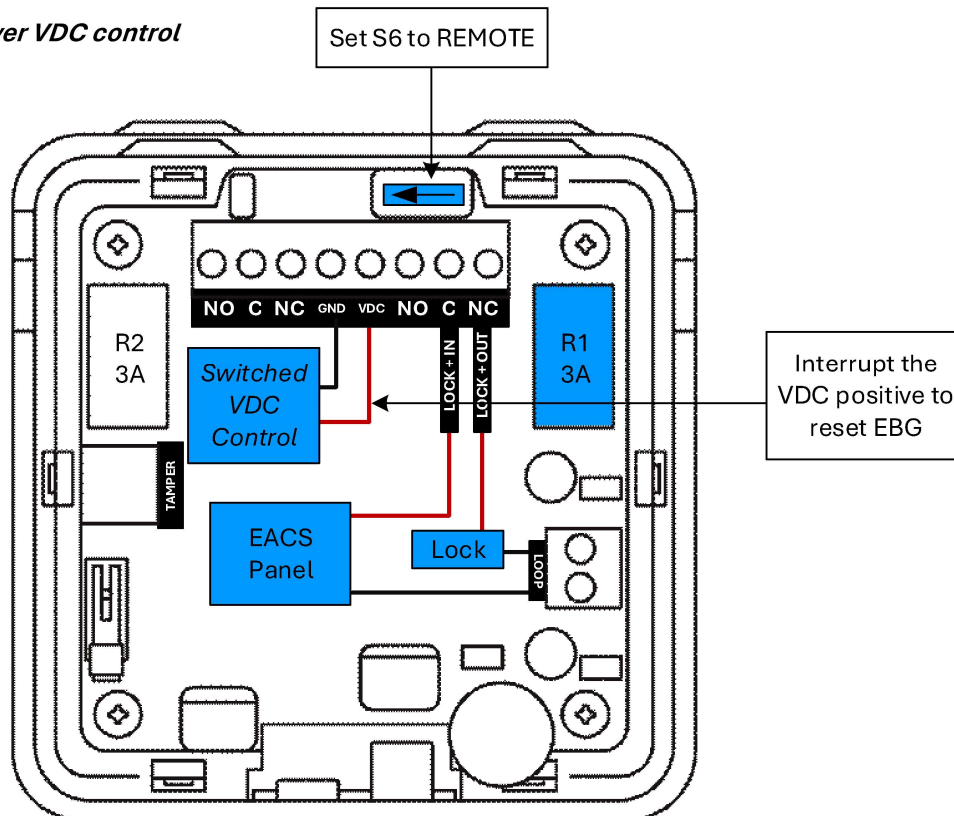

Notes:

- 1) The control voltage GND (J1) is linked to the LOOP terminal. Jack Fuse recommends using the same power supply for lock and control power to avoid grounding issues. Alternatively, the lock and EACS commons can be joined using a separate, isolated connector.
- 2) Be aware that if the control voltage is fire tripped then it will drop power to the EBG and unlock the door. This can be used as a redundant fire trip method but could cause difficulty in fault finding if the lock power is also fire tripped.
- 3) The mode type can be determined without opening the case by setting the door to free access (no lock power.) If the LED back lighting remains lit, then the EBG is using dedicated power control.
- 4) Relay 2 can be used as a break glass alarm monitoring output (J9 = ALARM) or as a secondary relay for cutting lock power or controlling an automatic door. (J9 = RELAY).

Automatic door/gate connections. Automatic doors and gates typically require a dry contact signal to open or release in an emergency. This requirement can be met using the EBG in both automatic and remote reset modes.

Automatic door - auto reset mode. To provide fully automatic reset control to an automatic door, the EBG is wired using the lock power control method described above. Instead of powering an electric lock, the lock power will drive a Jack Fuse Mini-FRI interface relay. This relay will, in turn, provide a dry contact to control the automatic door or gate.

It is best practice to locate the Mini-FRI relay close to or inside the automatic door/gate controls.

Fig. 10. Auto door with relay interface

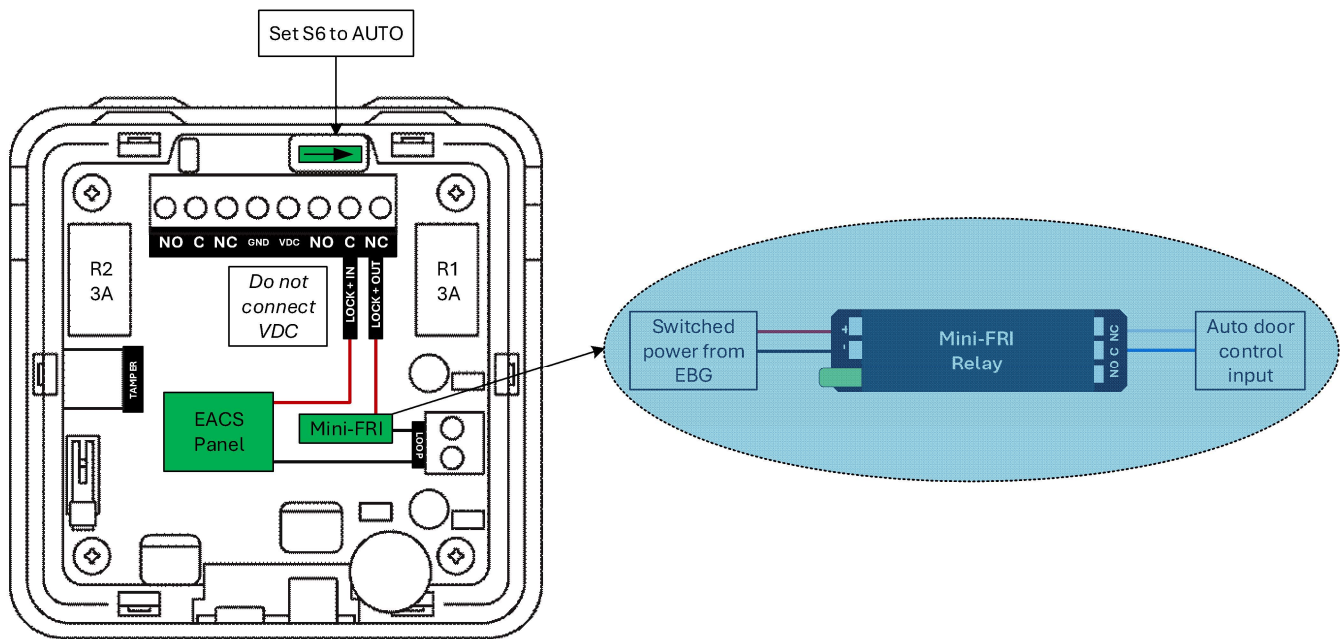

Note: In this mode, when the EBG is activated, the automatic door will either open or be placed into sensor (day) mode depending on which mode is connected. Either mode is acceptable for an EBG connection. To comply with Australian emergency egress regulations a separate direct fire trip connection should be used to open the door in the event of a fire alarm.

Note: If a push button door/gate input is used for the EBG connection it must keep the door activated and not reset until the EBG is reset.

Automatic door – remote reset mode. To utilise the dedicated voltage remote reset mode with an automatic door the EBG can provide a dry contact directly from relay 1 or 2.

Note: If relay 2 (R2) is to be used for door control ensure J9 is set to **RELAY**.

Fig. 11. Auto door with direct control

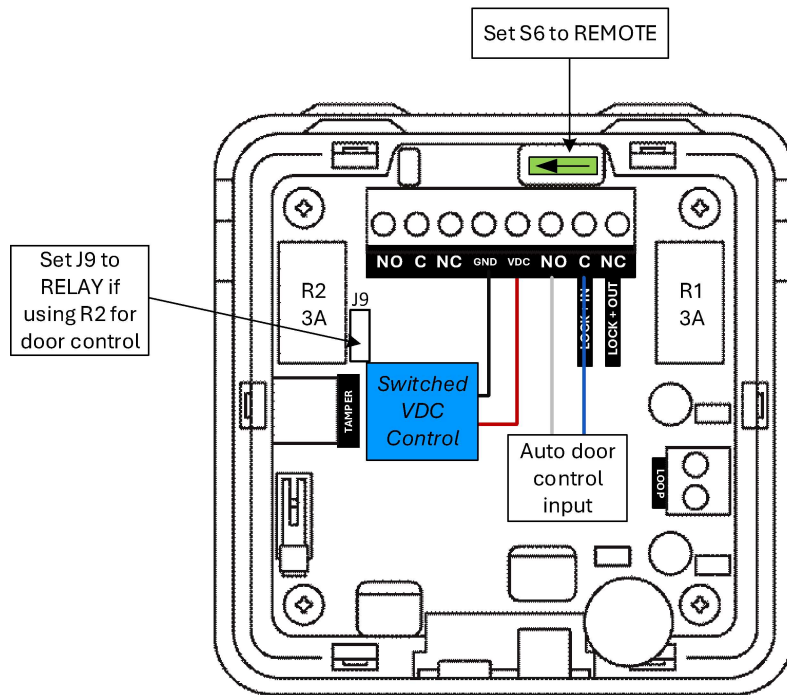

Constant Power Mode

In rare cases where switched lock power is not available or where remote/automatic reset is not desired, a constant DC voltage may be used to power the EBG.

Adding constant power to the VDC input and switching S6 to REMOTE will lock out the remote and automatic reset ability. LED back lighting and warning sounder functionality will still be available. In constant power mode the EBG can only be reset via the local reset button S5.

This mode can be useful when upgrading legacy break glass units connected to automatic doors. 12VDC can be sourced from reader power rather than re-wiring the access control connections. This allows the break glass dry contact connection to the automatic door to be retained.

EBG alarm and tamper monitoring

The tamper terminal (J2) provides a closed, dry contact that switches open on tamper activation. Relay 2 **C and NO** terminals can be used to monitor the EBG activation status. There are two options for monitoring both alarms. **Note:** If relay 2 (R2) is to be used for activation monitoring ensure J9 is set to **ALARM** (default).

- 1) Monitor the tamper in series with break glass monitoring via relay 2. This is the same method used when monitoring motion detectors. Place the EOL resistors in such a manner that an open circuit tamper alarm is provided when the tamper is activated. Ensure J9 is set to **ALARM**

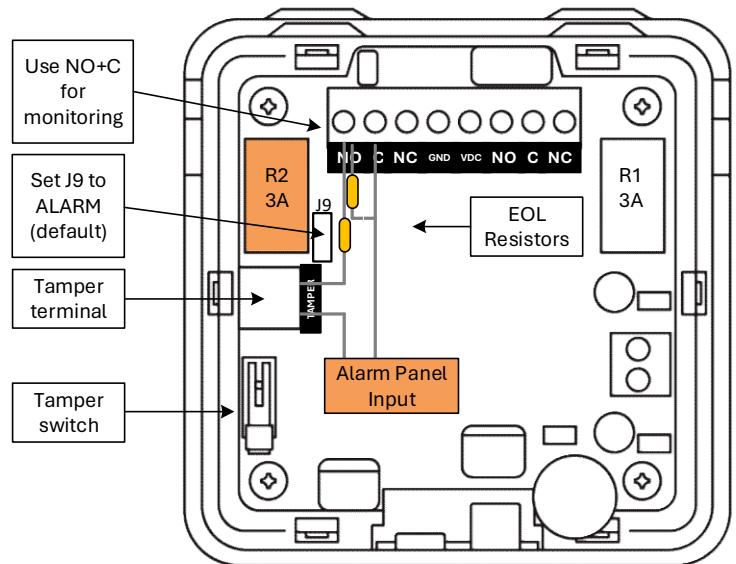

Fig. 12. Series tamper and alarm monitoring

- 2) Wire the tamper and alarm signals separately to alarm panel inputs via EOL resistors or an encrypted EOL module. This method is useful for high security applications. Ensure J9 is set to **ALARM**

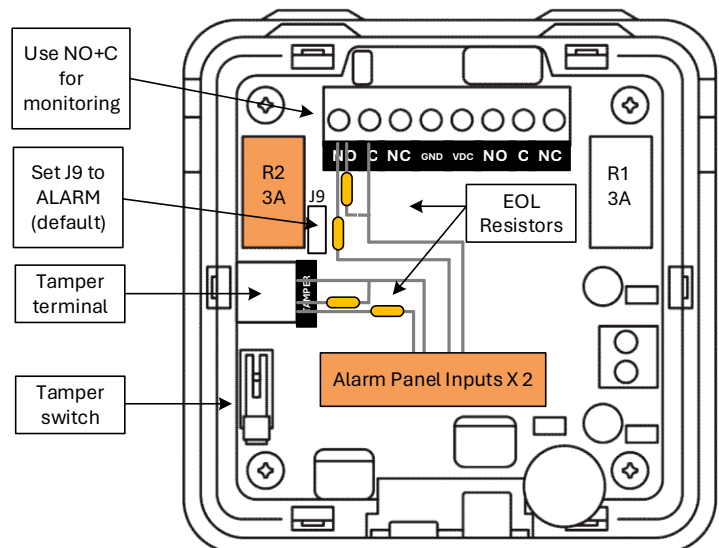

Fig. 13. Separate tamper & alarm monitoring

Note: Never use a break glass monitoring input as an emergency door release control in access control software. This practice makes it impossible to test the break glass contacts properly and may hide a fault that will not become evident until a real emergency exit is required.

Note: The EBG monitoring output will be in the ‘alarm’ state when the EBG is powered and latched on (activated). When the EBG is not powered or activated the monitoring output will remain sealed.

Low voltage operation. If the lock power at the door is subject to a large voltage drop and is falling below 12VDC, the EBG can be set to low voltage mode to assist operation and provide better performance from the activation indicators.

To activate low voltage mode, place the supplied jumper onto J7.

Warning. Do not use low voltage mode when the lock voltage at the EBG is greater than 13VDC.

Fig. 14. Low lock voltage

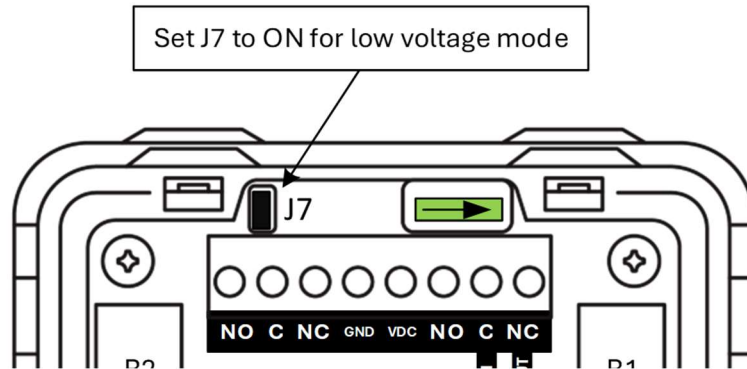

EBG status indicator. LED back lighting illuminates the EBG actuator. By default, green indicates the EBG is in standby mode. Red indicates activation and an absence of backlighting indicates no power is available.

The LED brightness can be adjusted via the VRLED potentiometer or disabled by removing jumper J5.

Activation sounder. The sounder will provide an audible warning when the EBG has been activated.

The sounder volume can be adjusted via the VRBUZ potentiometer or disabled by removing jumper J6.

Note: Use a #0 Phillips head screwdriver to gently adjust the potentiometers.

Fig. 16. LED and sounder control

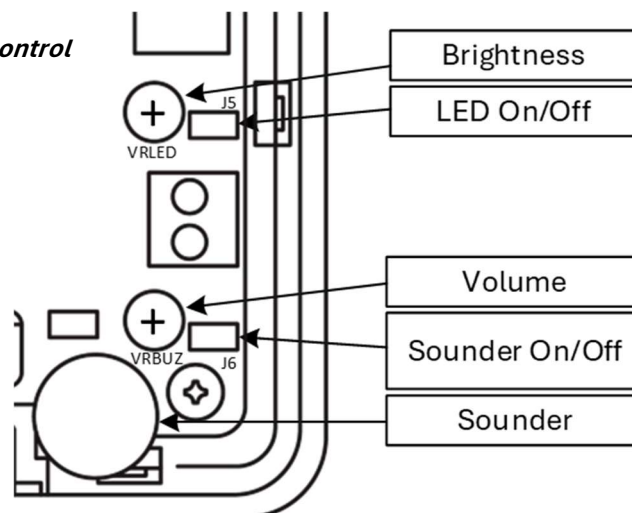

Simplified Connection Drawings

The below examples help explain common EBG connections.

Fig. 17. Lock power control, simplified wiring example

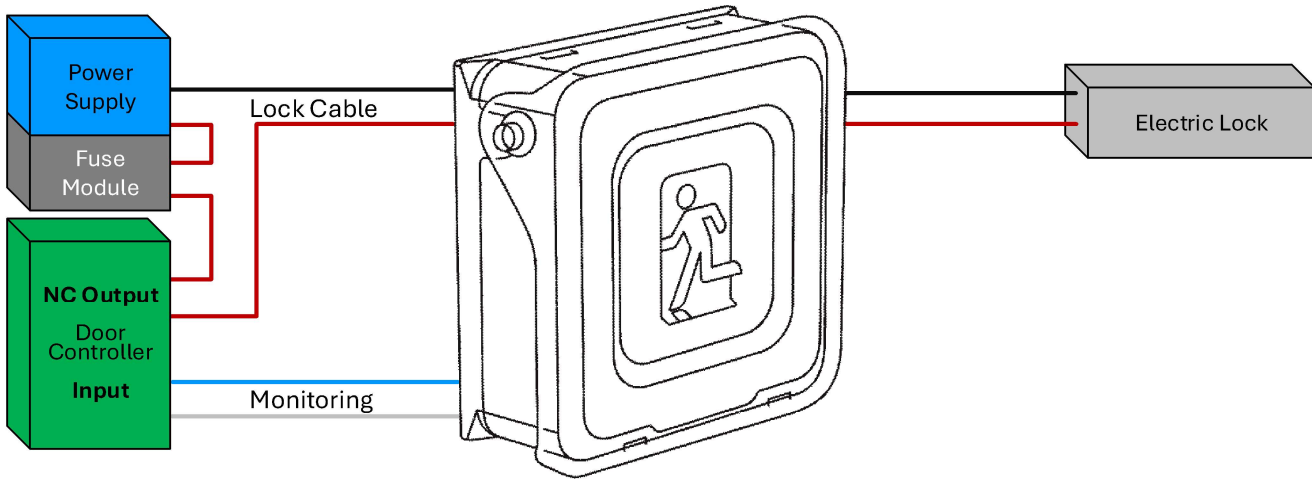
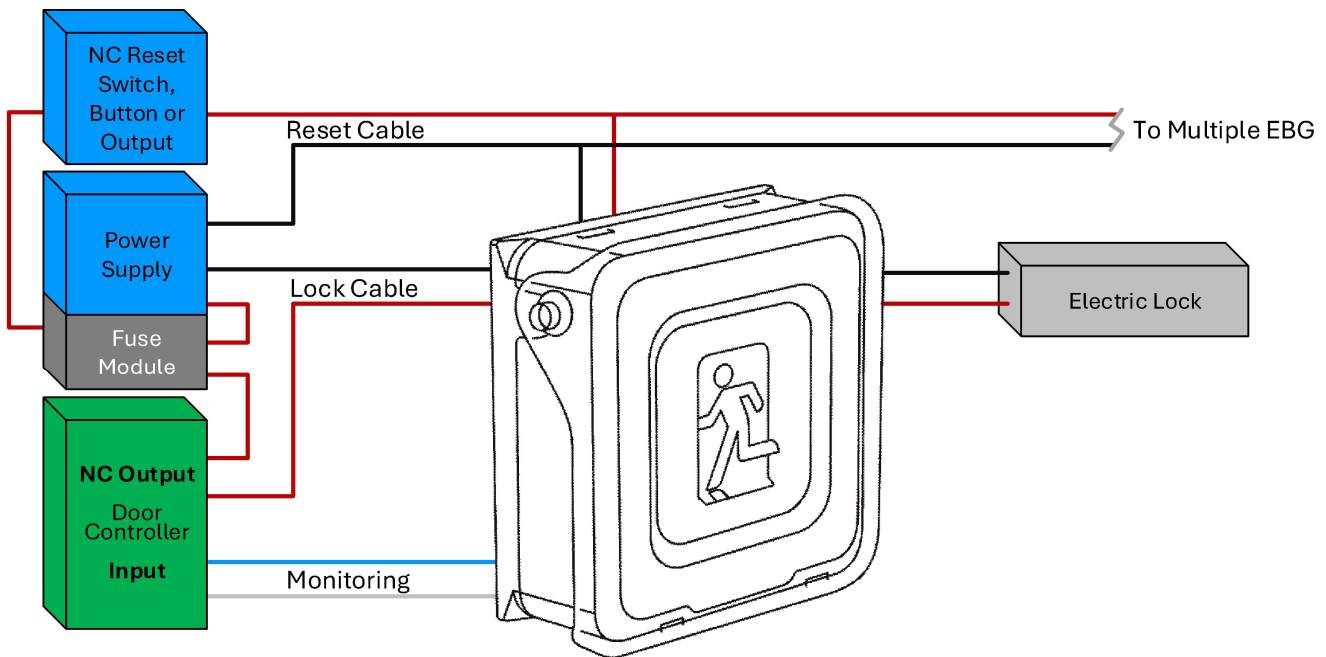

Fig. 18. Dedicated power control, simplified wiring example



Note: Jack Fuse recommends switching the positive conductor of lock power only. This includes fire trip, output and EBG connections.

Included Components

Each EBG-C is supplied with the following parts:

- Case plus facia and PCB attached with 4 x M3 self-tapping screws
- Running man actuator
- Base with tamper bracket attached
- Transparent activation cover
- 2 X 10mm M3 T10 security machine screws
- 2 X 35mm M3.5 machine screws for back box and wall box mounting

Maintenance Information

We recommend the EBG is tested to comply with local exit device regulations inline with the below instructions. Check local requirements.

Quarterly:

- While the associated door is locked, activate the EBG and ensure the door releases/opens.
- Reset the EBG and ensure door re-locks. (test, local, remote and auto reset if used).
- Note activation of LED's, sounder and alarm output.
- Clean as required with a soft cloth.
- Ensure no objects are obstructing the actuator or cover.
- Check EBG is mounted securely, and that the case screw is properly tightened.
- Ensure the EBG cuts lock power/activates the door directly and that the monitoring input is not being used to control the door.

As required:

- Activate tamper switch and ensure alarm transmission.

Technical Data

Conductor size – relays and common terminal	2.5mm ² (22-12AWG)
Conductor size – tamper terminal	1.5mm ² (26-14AWG)
Relay contact max current	3A
Relay contact configuration	SPDT (1 Form C) X 2
Tamper contact	NC 1A max
Power	55mA @ 13.8VDC (Sounder and Red LED on)
Operating voltage	12-28VDC*
Dimensions L X W X H	86X86X40mm (with cover)
RoHS	Compliant
AUS/NZ (RMC-EMC) 61000.6.3	Compliant
Primary materials	Polycarbonate, Polyamide 46, fiberglass,
Country of origin	China

*Lower voltages can be used. See *Low Voltage Operation* Section.

Ordering Code

EBG-C	Electronic Break Glass with guard
EBG-MB-C	Surface mounting back box with conduit knockouts
Mini-FRI-12	Relay for auto door/gate interface 12VDC
Mini-FRI-24	Relay for auto door/gate interface 24VDC

Learning

Become a **Jack Fuse Product and Power Certified Technician**. Free training available online.

More Information: For complete installation notes, data sheets and technical support please visit www.jackfuse.com