



**SCP V1
Safety Call Point**

Installation Note

Jack Fuse Safety Call Points are a range of duress style buttons with enhanced safety and reliability features.

This note applies to:
SCP-A - Assistance
SCP-D - Duress
SCP-L - Lockdown

Quick Reference

Fig. 1

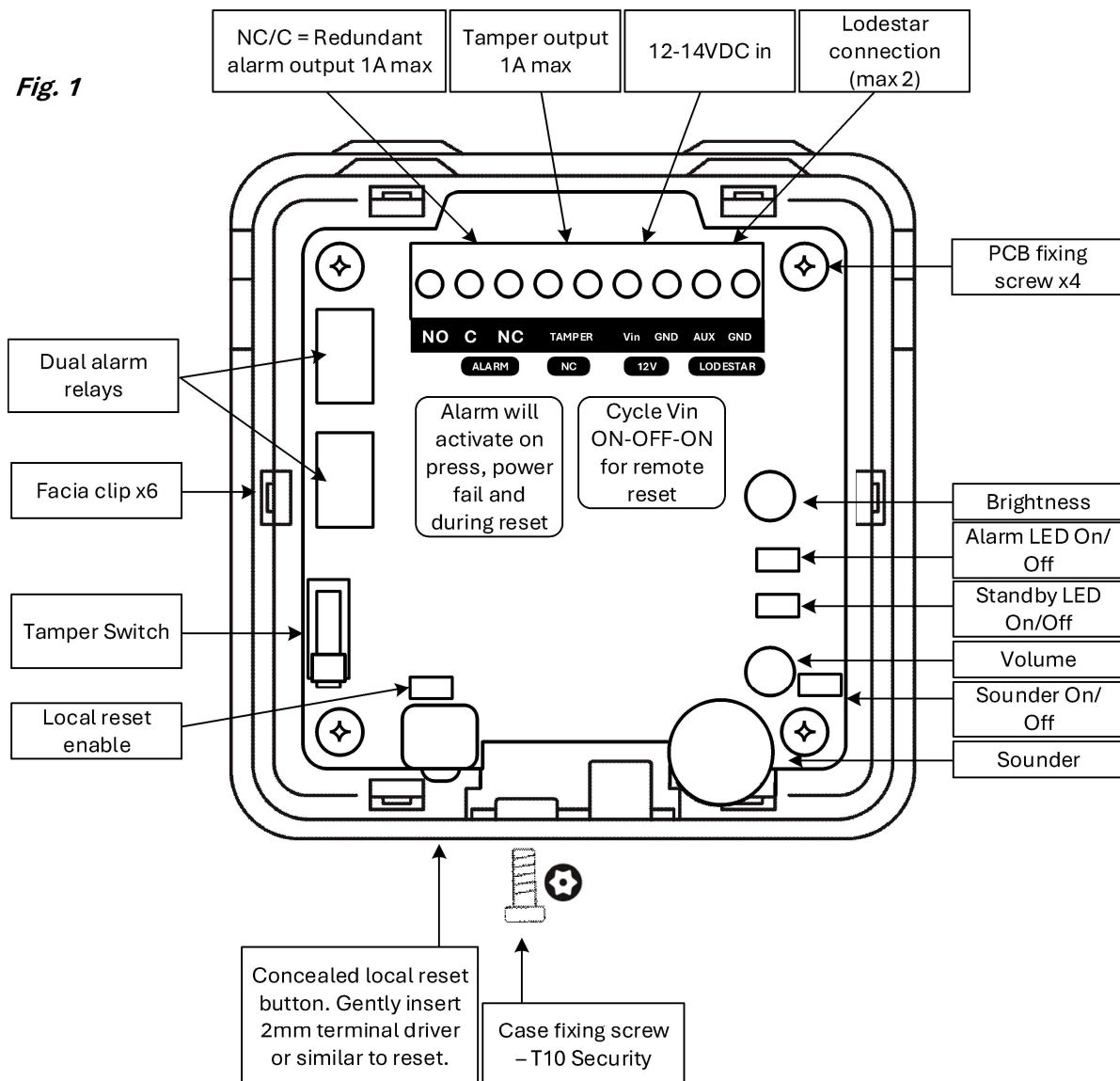

Alarm & Tamper Outputs

The SCP alarm output uses two relays in series to provide a redundant dry contact output. The relays work in tandem allowing the output to work even if one relay fails. The normally closed contact (closed in standby mode) provides this redundancy and is typically used for connection to an alarm input. The normally open contact is not redundant.

The alarm output will activate if the SCP actuator is pressed, if power to the unit is removed or if a reset is performed.

The alarm and tamper outputs may be combined and monitored via a single supervised input wired in the same configuration as a motion-detector with tamper. Alternatively, the outputs can be individually monitored.

Fig. 2. Alarm and tamper contacts in series. (DEOL shown)

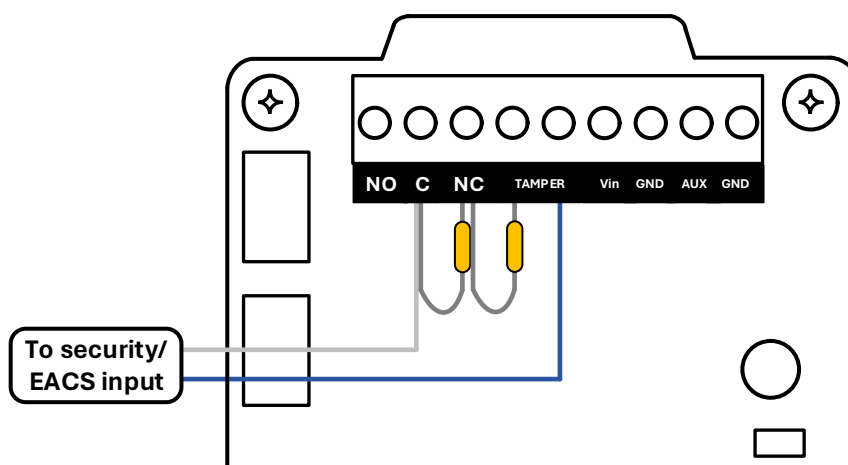
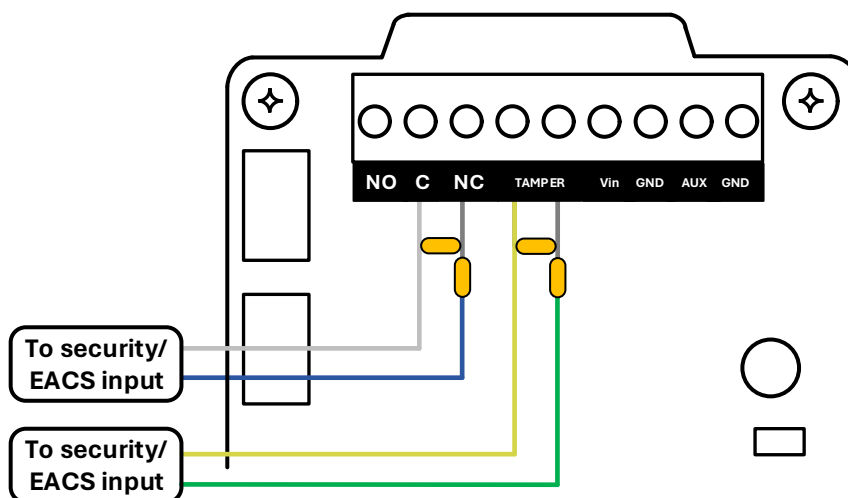

Fig. 3. Separate alarm and tamper monitoring



Power and Reset

The SCP requires a 12-14VDC power source to operate. (13.8VDC nominal.) Power is connected to the Vin and GND terminals taking care to observe correct polarity.

Remote reset is achieved by momentarily interrupting power to the SCP. Typically, this is done via a dedicated reset relay controlled by system software. This allows system operators to reset the SCP from a graphical user interface. Remote reset can also be achieved by interrupting power with a switch or button.

Cycle power (Vin) On-Off-On to reset. Power needs to be interrupted for approximately one second.

Fig. 4

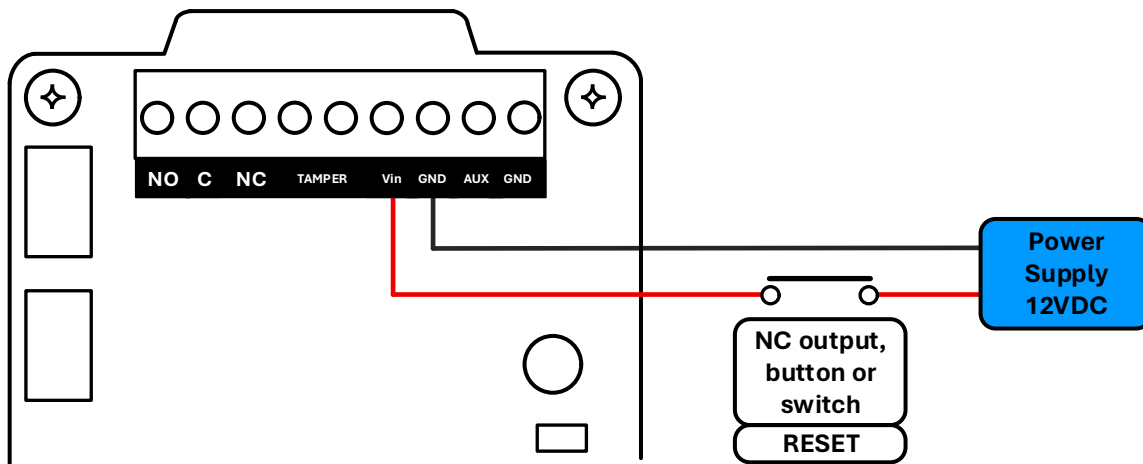

Note: The positive side of the power feed should be used for resetting. Interrupting the ground or negative side may cause unreliable results.

Common reset. SCPs may be grouped together and reset via a single output or switch. Note that the alarm output of grouped SCPs will all go into alarm during a reset.

Power distribution for redundancy and protection. The SCP power cable should be protected by a fuse (.5-1A) located close to the power supply. Jack Fuse recommends using an individual fuse for each SCP where possible. This ensure that an overcurrent event is less likely to affect multiple SCPs.

Grouping SCP' on one fuse will not, however affect normal SCP operation. Ensure grouped SCPs are protected by a fuse that has a rating greater than the total current consumption but lower than the current rating of the smallest cable used.

The Jack Fuse PP10HD is suitable for distributed power protection of SCP cabling.

Local reset. A reset button is located on the underside of the SCP. Insert a 2mm terminal driver (or similar shaped tool) gently into the hole marked with a reset symbol  until a resistance and then a click is felt.

The local reset can be disabled by removing jumper J3 on the PCB.

Fig. 5

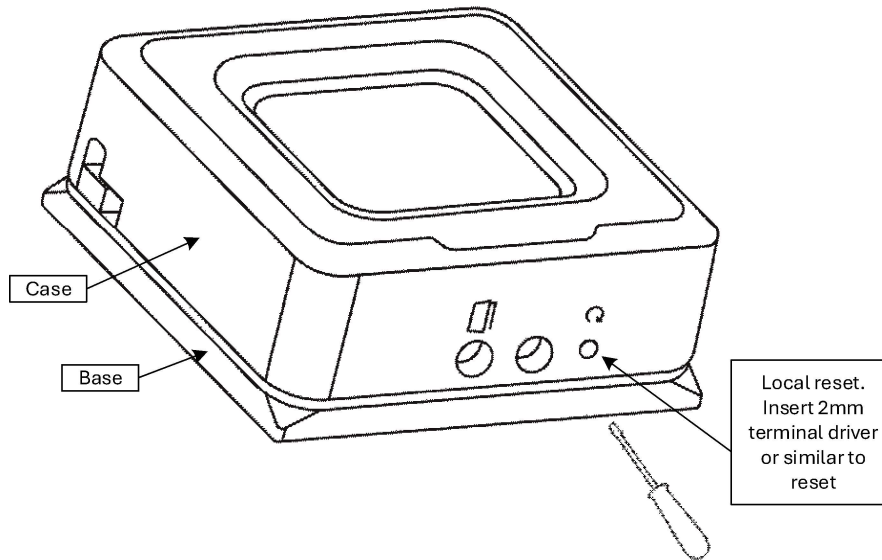

Mounting & Tamper Bracket

Base mounting. The SCP base may be mounted directly to the wall using the holes provided.

Mounting holes and screws are also provided to allow the base to be fitted to an optional surface back box (EBG-MB-C) or an electrical wall box.

Fig. 6. Base & mounting options

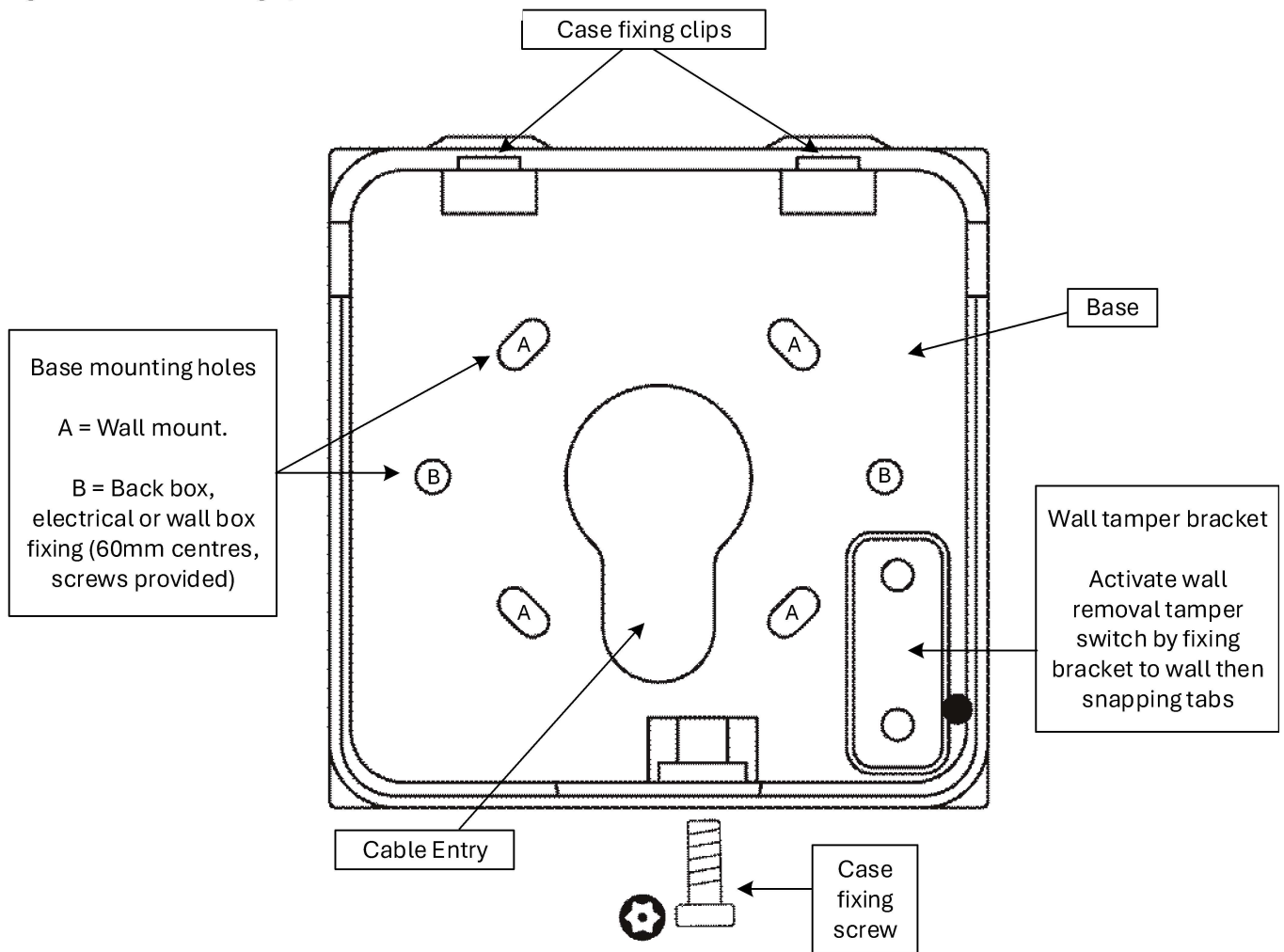

Wall Tamper. The case tamper switch can optionally monitor the SCP for removal from the wall. The wall tamper bracket is attached to the base by small tabs that need to be broken to activate the wall tamper.

Fix both the base and the wall tamper bracket to the wall at the same time. Remove the base fixing screws and pull on the base to snap the bracket tabs. This will leave the wall tamper bracket in place on the wall. Re-affix the base as normal.

Note: If mounting the SCP on a back box or electrical wall box, do not detach the wall tamper bracket.

Activation Guard. Each SCP is fitted with an activation guard. The guard can be removed/re-fitted only when the case has been opened.

Fig. 7

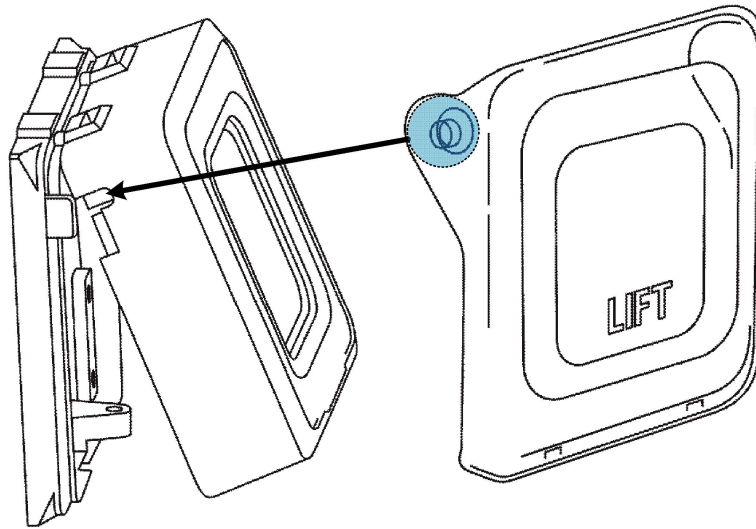
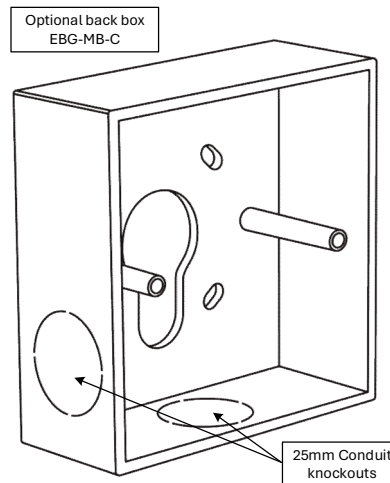

Fig. 8 Optional surface mount back box.



Auxiliary output - Lodestar

The AUX output will provide VDC out during an SCP activation. This voltage can be used to drive separate alarm indicators to help responders locate and identify an alarm efficiently.

A maximum of two Jack Fuse Lodestars can be connected to the AUX output.

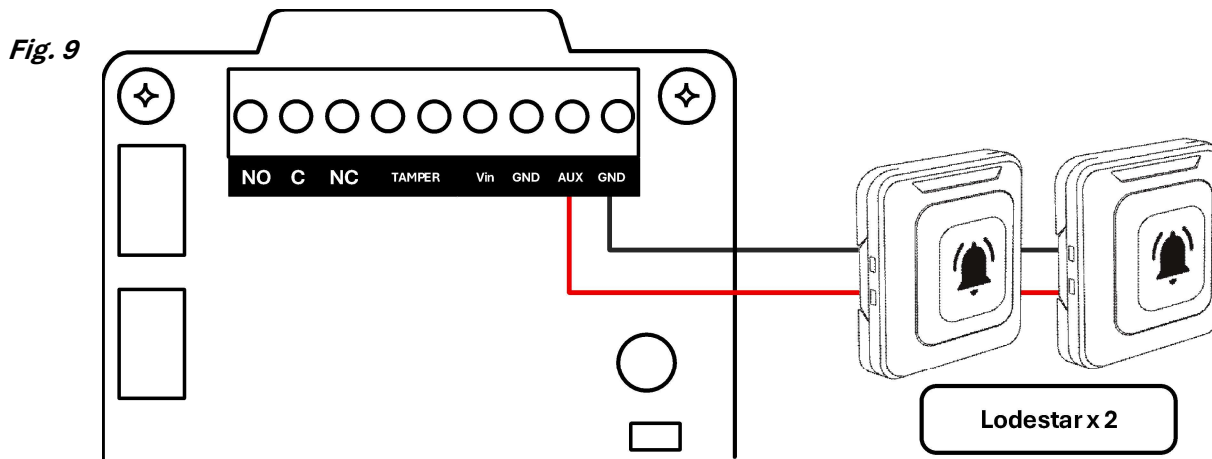

LED & Sounder Control

In standby mode the SCP actuator is back lit with a LED colour that matches the SCP model.

- **SCP-A – Assistance – Orange**
- **SCP-D – Duress – Yellow/Orange**
- **SCP-L – Lockdown – Blue**

Upon activation the LED colour changes to red and a warning will sound.

The activation warning sounder volume can be adjusted to suit each application using the VRBUZ potentiometer or disabled using jumper J6.

The VRLED potentiometer is used to adjust the LED brightness. Note the brightness adjustment will affect both the standby and activation LEDs.

The standby and activation LEDs can be enabled/disabled independently using J4 and J5.

Fig. 10

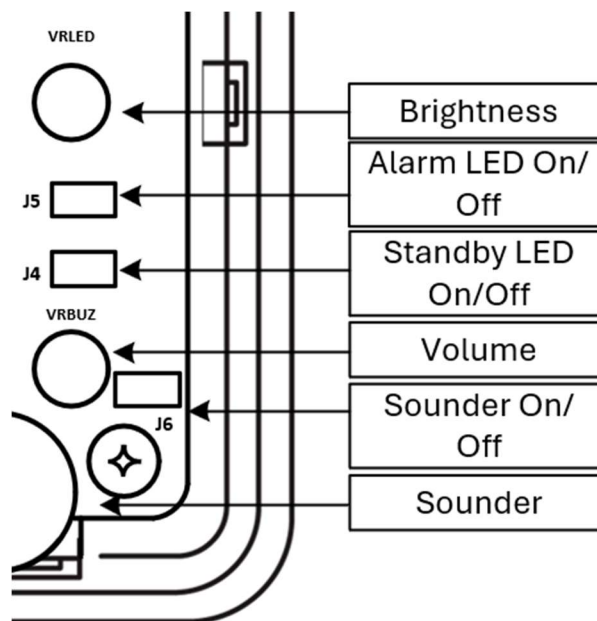

Note: Use a #0 Phillips head screwdriver to gently adjust the potentiometers.

Included Components

Each SCP is supplied with the following parts:

- Case, facia and PCB attached with 4 x M3 self-tapping screws
- Actuator
- Base with tamper bracket attached
- Transparent activation cover
- 1 X 10mm M3 T10 security machine screw
- 2 X 35mm M3.5 machine screws for surface and wall box mounting

Maintenance Information

We recommend the SCP is tested to comply with local regulations and requirements, in line with the instructions below.

Quarterly:

- Press actuator, confirm alarm transmission and LED status change
- Confirm local reset function (if enabled) otherwise perform power reset
- Press actuator, confirm external alarm indicator function if fitted
- Reset
- Clean surface dust/dirt with a soft dry cloth
- Confirm unit is securely mounted and not obstructed in any way

As required:

- Activate tamper switch and ensure alarm transmission

Technical Data

Conductor size – terminals	2.5mm ² (22-12AWG)
Relay contact max current	1A
Relay contact configuration	SPDT (1 Form C) NC redundant NO non-redundant
Aux output	100mA, 12VDC (Vin)
Tamper contact	NC 1A max
Power	70mA @ 13.8VDC (not including AUX)
Operating voltage	12-14VDC (13.8VDC nominal)
Dimensions L X W X H	86X86X40mm (with cover)
RoHS	Compliant
AUS/NZ (RMC-EMC) 61000.6.3/4	Compliant
Primary materials	Polycarbonate, Polyamide 46, fiberglass,
Country of origin	China
Recommended cable (tamper shared with alarm)	Four core security (14/020)
Recommended cable (separate tamper monitoring)	Six core security

Ordering Code

SCP-A	Safety Call Point – Assistance - Orange
SCP-D	Safety Call Point – Duress - Yellow
SCP-L	Safety Call Point – Lockdown- Blue
EBG-MB-C	Surface mounting block with conduit knockouts
Lodestar-W	Versatile Alarm Status Indicator - White
Lodestar-C	Versatile Alarm Status Indicator - Charcoal
SCAR-C	Dress plate used when upgrading from existing single gang buttons (coming soon)

Learning

Become a **Jack Fuse Product and Power Certified Technician**. Free training available online.

More Information: For complete installation notes, data sheets and technical support please visit www.jackfuse.com